



Bamboo outdoor decking

"The replacement for tropical hardwood which doesn't involve any tree"



StrongBoo

outdoor decking

Bamboo

is officially a type of grass and therefore a completely natural and sustainable product. When Bamboo is between 3 and 5 years it has reached a length of about 30 meters and is suitable to be chopped. This in contrast to tropical hardwood where the growth process takes about 50 years.

During the growth process, an enormous amount of CO₂ is converted into oxygen, which makes the endproduct CO₂ neutral. During harvesting the roots remain in the ground from which a new growth will be achieved. Therefore there is no damage to the soil and the environment. This is beneficial for the local biodiversity. Soil erosion is minimized as a result. Hardwood on the other hand is cut down with heavy machinery and doesn't grow back. As is known deforestation is a major global problem.

Strongboo outdoor decking are therefore very attractive and can be delivered quickly and easily from stock.

Available in the colours:

- middle brown
- extreme dark brown/black

Length:

- 1860x138x20mm

Other sizes and thicknesses available on request.

The boards can be invisibly fixed with separately available steel clips.

Finally, with a bamboo decking you don't only have a sustainable product but also a product with a natural wooden look, without the disadvantageous aspects of tropical hardwood.



Important information about **StrongBoo** outdoor decking

The StrongBoo bamboo boards are a natural product that can vary in colour and structure within the same bamboo species.

Over time, decking boards can appear worn from exposure to the elements, water, sunlights, dirt and other external factors. Deformation and/or sagging of the boards may occur after installation. This is quite normal in most wood species and is minimized in this product by the heat treatment.

Cracks and chips in the surface can occur due to the different drying of the surface and the front edges. In addition, the surface will become a little rougher.

We recommend treating StrongBoo bamboo boards with a water-based oil immediately after installation.

With corrugated boards, the deformation caused by weathering is less visible than with smooth side boards. Deformation of the decking surface is not considered a material defect. Roughness and chipping of decking boards can be reduced by proper cleaning and care of the decking. This can be done with a silicon carbide brush or a silicon carbide disc machine.

Installation

Important information for the installation:

- The panels should be stored in a dry place to avoid sunlight and rain.
- A water-permeable soil structure is important to ensure that water does not accumulate. For example, by using sand and gravel as soil layers.
- To ensure that the lower joists do not touch the ground, stable cement blocks or height-adjustable posts/feet should be placed under them. Bottom joists should be a minimum of 40x50 and made of bamboo, recycled plastic, or hardwood. The connection of the lower beams can be done with screws and outdoor glue with a gap of about 5-8mm.
- To prevent weed growth, it is important to install root cloths.
- The decking boards need a slight slope of 1 - 2% so that the water can run off the boards. It's also possible not to do this, but then the water will stay on the surface longer, potentially causing more surface cracking. Without a gradient, more maintenance/cleaning is required.
- It is important that the decking boards have space to dry on all sides. Therefore, make sure that there is at least 2 mm space for ventilation.
- The distance between the subfloor and the decking boards should be between 80 mm and 150 mm. With a sub-floor that cannot dry quickly, the distance between the sub-floor and the bamboo planks should be at least 100 mm.
- In the case of a single beam construction, this should be attached to the substructure underneath. If this is not possible, use a rhombus construction.
- The bottom joists should have a maximum distance of 375-400mm between centres. This means 5 sub-beams per bamboo plank. The ends of the bamboo decking boards should always be fitted to the joists with a gap of 2-5mm.
- If you decide to use a random connection, the beams should be spaced 275-300 mm apart.



Mounting with stainless steel/ox clips and screw

Mounting with stainless steel/ox clips and screw

- Mount cement blocks or tiles or height adjustable legs/posts.
- Attach a suitable, stable and immovable substructure made of bamboo, recycled plastic or hardwood to the cement blocks or tiles.
- Decide which side of the board will serve as the top side: the ribbed side or the smooth side.
- Place the clip in the groove of the bamboo plank.
- Drill a hole for the screw 20mm from the side and thread the screw $\frac{3}{4}$ into the bracket and beam without fully tightening.
- Insert the next decking board.
- Thread the screw fully into the bracket and bottom beam. The screws should always be screwed in at right angles to the beam.
- For best results, use only the included stainless steel brackets and screws.
- StrongBoo recommends treating the planks with a good quality water-based oil immediately after installation.

Mounting with stainless steel screws

- Mount a cement block or tile or height adjustable legs/poles.
- Attach a suitable, stable and immovable substructure made of bamboo, recycled plastic or hardwood to the cement blocks or tiles.
- Decide which side of the board will serve as the top: the ribbed side or the plain side.
- Drill a hole for the screw 20mm from the left and right side.
- Use stainless steel screws to fasten StrongBoo bamboo decking.

The StrongBoo installation guide describes the standard installation, but StrongBoo should be contacted for special circumstances. Under the special circumstances, these assembly instructions cannot be considered binding.

Sample drawings of the substructure and assembly

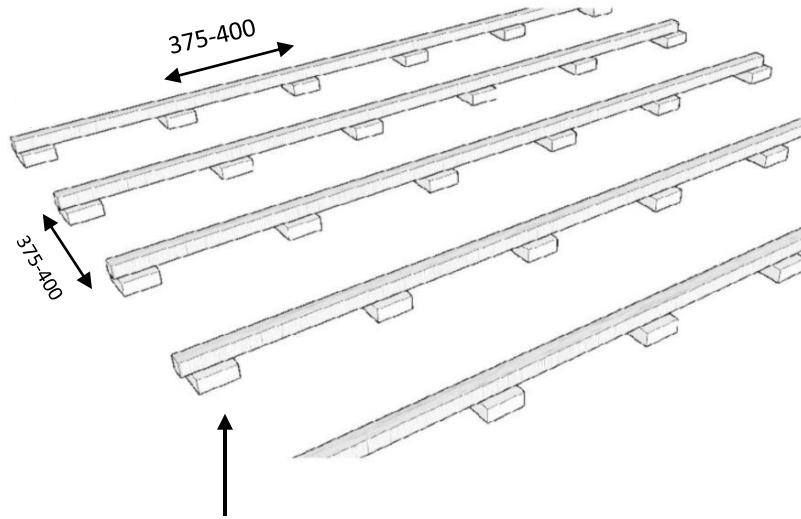

Cement tiles under the beams.

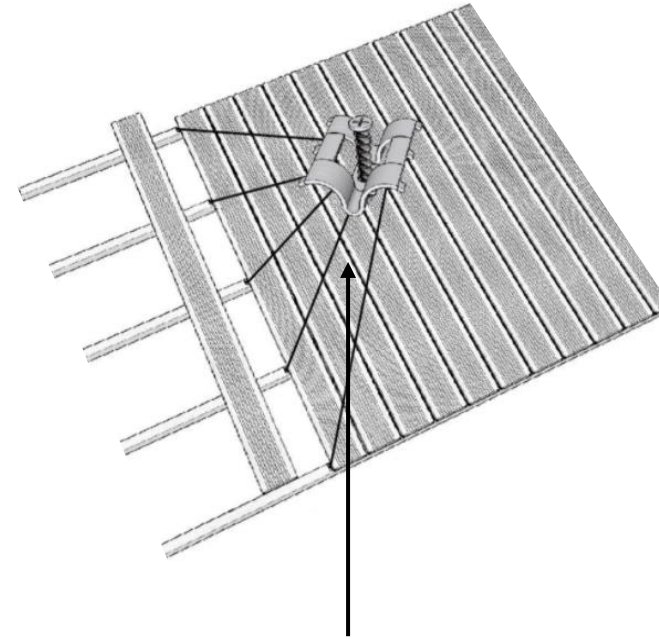

The special fastening clamps made of stainless steel are available from stock and enable almost invisible attachment to the substructure

Fastening detail with clip closure

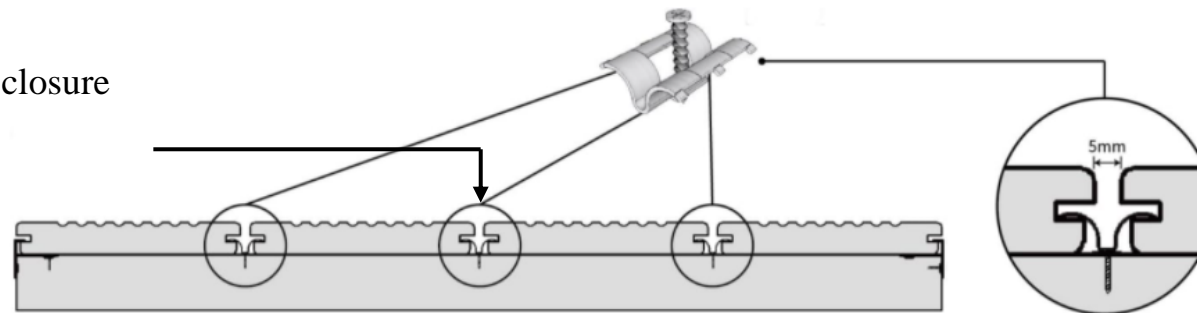

Brown bamboo outdoor decking



Cleaning and maintenance

StrongBoo bamboo planks are pre-oiled on both sides

The first maintenance should be carried out immediately after laying. After that, we recommend cleaning the bamboo decking with a good quality oil once every six months. This oil is available from us as an accessory. Depending on the usage situation, it may be necessary to clean and care for your bamboo planks several times a year.

Cleaning

1. Clean your StrongBoo bamboo deck with deck cleaner, water and a broom. Use a special cleaner to remove dirt, and then clean with a brush. A high-pressure cleaner is not permitted.
2. Scrub decking lengthways until completely clean.
3. Rinse the decking boards well with clear water, remove any cleaning residue and allow the floor to dry completely naturally (approx. 24 hours). Only when all materials are completely dry can the oil be applied.

Oil

4. Stir the oil well before use. Apply an even layer of oil with a brush..
5. Only apply the oil in dry weather and avoid direct sunlight and high temperatures.
6. Allow the oil to dry for about 30-45 minutes and repeat the above step.
7. Depending on the weather, it will take between 24 and 48 hours for the oil to dry completely. During the drying process, the bamboo planks must not come into contact with water.

If you do not maintain the bamboo planks 1-2 times a year, the bamboo planks will discolour.

StrongBoo advises you to keep the bamboo decking free of dust and dirt as much as possible by regularly cleaning your deck with a broom.

Extreme darkbrown/black bamboo outdoor decking



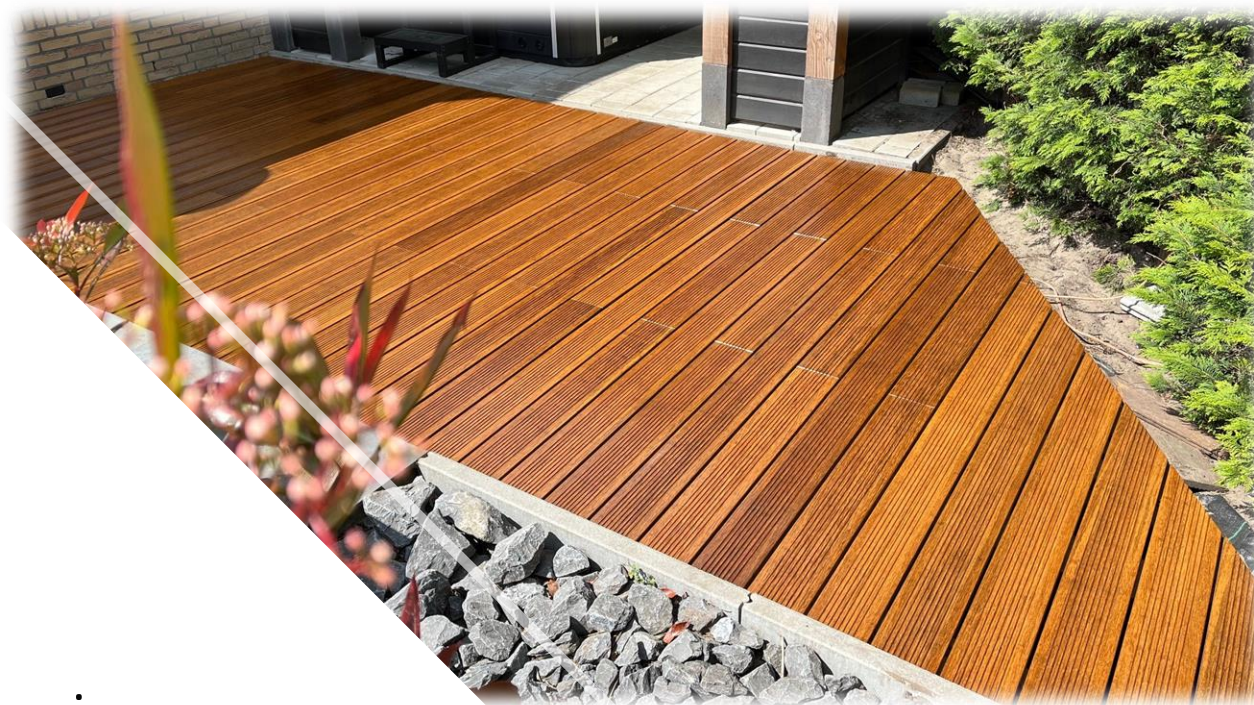

Impression



For more information please contact us or visit our office to see everything.

The coffee is always ready for you!

Company information

StrongBoo B.V.
Hulsenboschstraat 37
4251 LR Werkendam
Nederland

+31 (0)183 - 76 90 86

info@strongboo.nl

www.strongboo.nl